

Grain Lovers

INSTRUCTION MANUAL

Table-Flaker



Please be sure to read the operating instructions before use.
This will avoid possible harm and damage.

TASTE - FEEL - EXPLORE

make the most of grains

taste

FRESHLY
FLAKED

TASTES BETTER

feel

HOMEMADE
IS GOOD
FOR YOU

AND EASY TO DIGEST

explore

FRESH
FLAKE
FLAVOUR

IN NO TIME AT ALL



JOIN THE FOOD REVOLUTION

A warm welcome,

We are delighted that you have decided in favour of the Table-Flaker and welcome you to the world of grains.

Taste: Freshly flaked tastes better

Feel: Homemade is good for you and easy to digest

Explore: Fresh flake flavour in no time at all

Try out your Table-Flaker right away and enjoy the great flavour and aroma of freshly flaked whole grains.

We hope you enjoy discovering and savouring new individual creations. We also look forward to your feedback.

Best regards

Martina & Grainlovers Team

Nice to have you with us!



Contents

Welcome _____	Page 3
Precautions/Safety notices _____	Page 6
Components _____	Page 7
Getting started _____	Page 8
Maintenance _____	Page 9
Removing the hopper _____	Page 10
Cleaning the hopper _____	Page 11
Removing the crank handle _____	Page 12
What the Table-Flaker can do _____	Page 14
Technical data and scope of delivery _____	Page 15
Warranty and repair _____	Page 16
Do you have any questions? _____	Page 17
Notes _____	Page 18
Contact us _____	back page

PRECAUTIONS AND SAFETY INSTRUCTIONS

Before using your Table-Flaker for the first time, please read the operating instructions carefully.

Selection of the grain

Only buy cleaned grains. Unclean grain may contain small stones that can damage the rollers. Flaking grains other than those listed on page 14 can damage the appliance and invalidate the warranty. The variety of options is enormous, so if you want to process other grain, please contact us by email at info@grainlovers.shop.

Cleaning

The Table-Flaker must not be immersed in water or other liquids. The housing can be cleaned with a damp cloth. The rollers should never come into contact with water (see also section „Cleaning the hopper“, p. 11).

Warning

Never reach into the roller or insert objects (e.g. spoons, screwdrivers, etc.). Failure to do so may result in injuries and damage to the rollers.

Supervision

The table flaker may only be operated by adults.

OPERATING ELEMENTS

- A: Hopper
- B: Crank handle
- C: Housing
- D: Stand

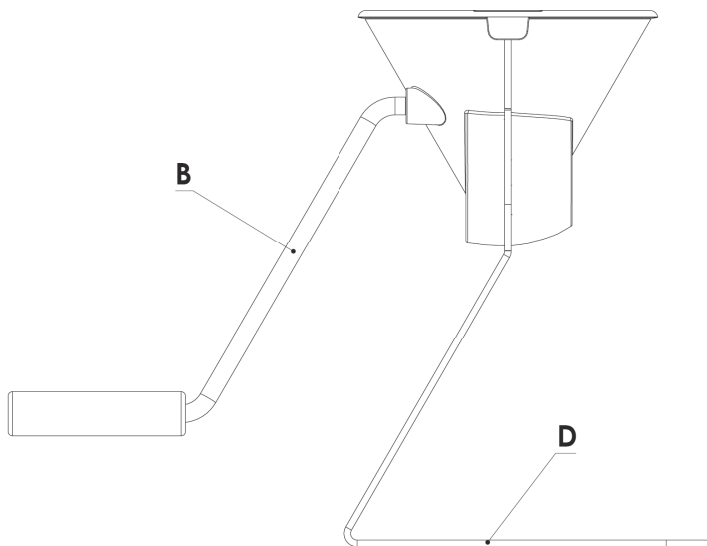
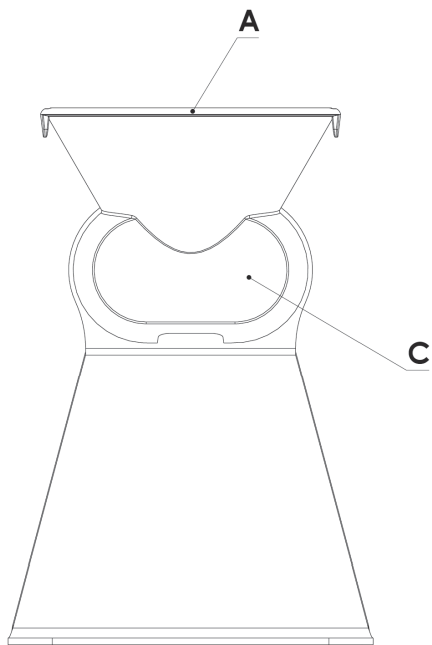

Getting started

Before first use please follow the instructions below in order.

1. Place the Table-Flaker on a clean and level work surface e.g. table or worktop. Make sure that the anti-slip rubber on the base of the appliance is clean to increase the stability of the Table-Flaker.
2. Fill the funnel with a handful of oats and place a bowl under the outlet.
3. Fasten the crank by screwing it clockwise into the crankshaft until the rollers turn with the rotation.
4. Make sure that the table flaker is not too far away from you, so that you can apply more pressure to the funnel, see point 5. This allows you to operate the table flaker in a safe position.
5. Now press firmly on the funnel with one hand and turn the crank clockwise with the other hand until all the grains have been squeezed through. Discard the first flakes, as they may contain impurities from the manufacturing process of the rollers.
6. Now you're ready to go: Your table flaker is ready for use.

MAINTENANCE

Cleaning

We recommend cleaning the rollers during longer periods of downtime, e.g. before going on holiday. This is very easy to do. Disassemble the table flaker as shown in the pictures and use a brush to remove any flake residue from the rollers. Then reassemble the table flaker (see also the demo video on our website at: www.grainlovers.shop)

→ Help/Support

Video instructions for cleaning.

Scan the QR code with your smartphone to access the video.



REMOVING THE HOPPER

To remove the crank or for cleaning, you must first remove the hopper. To do this, pull the clamping wings „slightly“ outwards and lift the upper part of the hopper upwards, see illustration.



CLEANING

Before cleaning the rollers, you must first remove the hopper as explained on the previous page. Once this is removed, you can see the roller mechanism.

Now you can clean the rollers with a brush by turning them anti-clockwise and pressing the brush against the rollers. The loosened grain residues fall out when you turn the table flaker over.

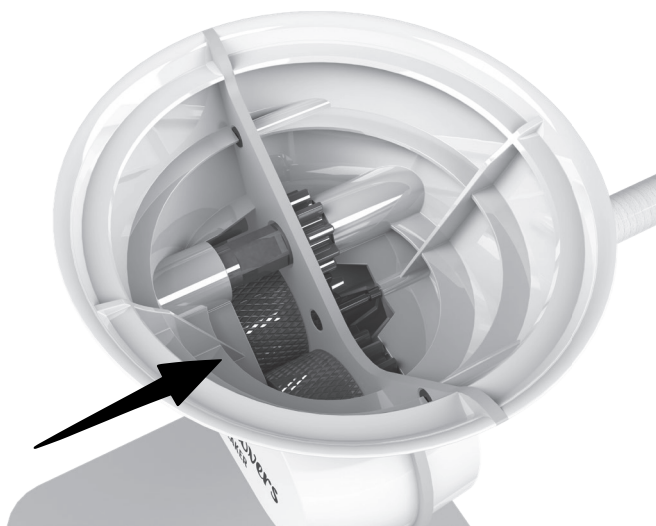

REMOVING THE CRANK HANDLE IF NECESSARY

First remove the upper part of the hopper as described on page 10. Once you have removed it, you can see the roller mechanism. Take care not to get your fingers into the spaces between the moving parts (such as rollers, gear wheels). There is a risk of injury if you turn the crank at the same time.

To remove the crank, use the enclosed open-end spanner (spanner size 11mm). Fix the crankshaft with the spanner (as shown in the following pictures). Now turn the crank slowly anti-clockwise **while holding the open-end spanner in place**. This allows you to loosen and remove the crank.



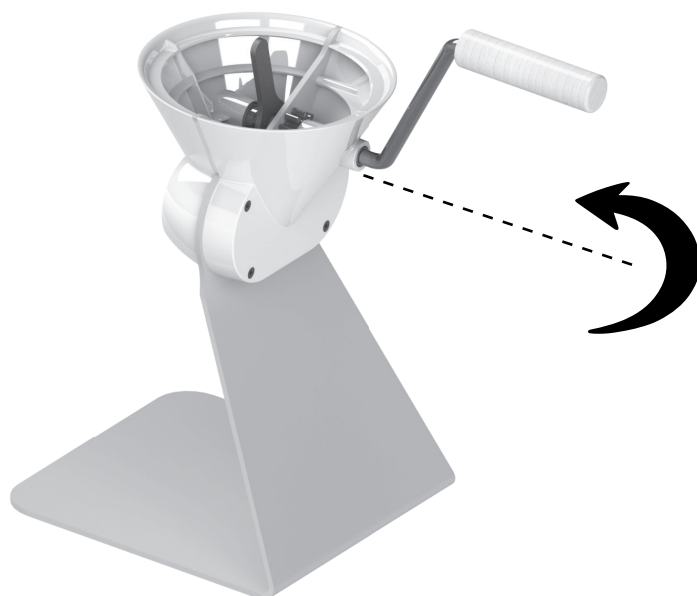
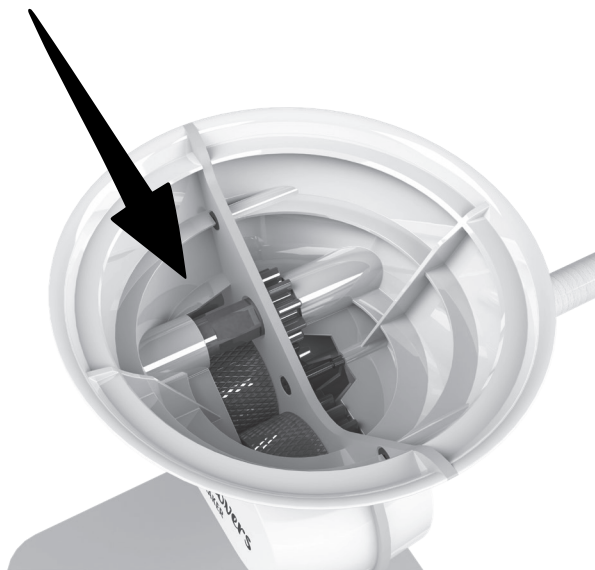

WHAT CAN THE TABLE-FLAKER DO?

The table flaker transforms oat grains into oat flakes in no time at all.

WHAT ELSE IS POSSIBLE?

The table flaker can break up brown millet, buckwheat, golden millet, hemp seeds, linseed, quinoa and sesame.

FINALLY,

Einkorn and naked barley can also be flaked, **BUT CAUTION:** Before flaking, briefly soak the grains in the kitchen sieve under the tap. Then spread the grains out on a towel and leave to dry until no more moisture adheres. If the grains are left to dry beyond this point, the flour bodies will lose the moisture they have absorbed and the flakes will tend to become brittle when crushed.

TECHNICAL DATA AND DELIVERY SCOPE

Designation:

Table-Flaker

Crank handle

Stainless steel and beech

Crushing capacity:

Depending on crank speed
approx. 35 g/min

Stand:

Powder-coated steel

Hopper filling:

110 g

Dimensions: 16,5x17x24,5 cm

With crank: 16,5x32x24,5 cm

Crushing unit:

Stainless steel rollers and shafts

Weight:

2,1 kg

Housing

Plastic - ABS

Guarantee:

2 years

Colour:

White/silver grey

Subject to change due to technical reasons.

Scope of delivery:

Table flaker with crank, funnel insert,
spanner, operating instructions

Further questions?

Our hotline:
+49 6162 50 99 66 0
email:
info@grainlovers.shop

WARRANTY AND REPAIR

The Table-Flaker is guaranteed by Wolfgang Mock GmbH for non commercial use against material and manufacturing defects for a period of 2 years from the date of purchase. Please register your device online under www.grainlovers.shop → Guarantee to ensure that your warranty is valid.

If a repair is necessary, please call or email us at info@grainlovers.shop before sending us the defective device. We can then inform you of the nearest authorised service centre.

The serial number can be found on the underneath of the stand.

Further questions?

Our hotline:
+49 6162 50 99 66 0
email:
info@grainlovers.shop

FURTHER QUESTIONS?

Our hotline: +49 6162 50 99 66 0

Email: info@grainlovers.shop

FURTHER APPLICATION INSTRUCTIONS

On our homepage at: www.grainlovers.shop you will find videos for further application tips.

TROUBLESHOOTING

If a problem occurs with your Table-Flaker or if you have any questions please contact us. Our specialist staff can assist you in all matters.

NOTES

NOTES

**MADE IN
GERMANY**

Grain  **lovers**

WOLFGANG MOCK GMBH
Marie - Curie - Str. 5
64823 Groß - Umstadt
Germany

+49 61 62 -50 99 66 0

info@grainlovers.shop

www.grainlovers.shop

